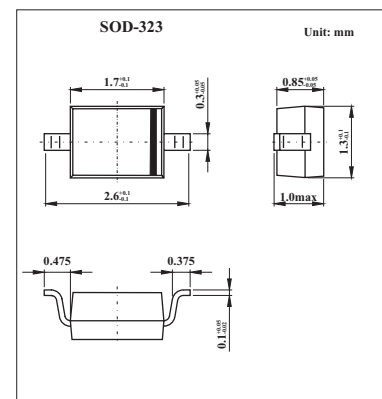

## Schottky Barrier Diodes

## 1N5818WS

## ■ Features

- Power Dissipation:  $P_D = 200\text{mW}$
- Collector Current:  $I_F = 1\text{A}$
- Collector-Base Voltage:  $V_R = 30\text{V}$

■ Absolute Maximum Ratings  $T_a = 25^\circ\text{C}$ 

Parameter	Symbol	Rating	Unit
Collector Current	$I_F$	1	A
Collector-Base Voltage	$V_R$	30	V
Power Dissipation	$P_D$	200	mW
Operating and Storage Junction Temperature Range	$T_j, T_{STG}$	-55 to +150	$^\circ\text{C}$

■ Electrical Characteristics  $T_a = 25^\circ\text{C}$ 

Parameter	Symbol	Testconditions	Min	Typ	Max	Unit
Reverse Breakdown Voltage	$V_{(BR)R}$	$I_R = 1\text{mA}$	30			V
Forward Voltage	$V_F$	$I_F = 1\text{A}$			0.55	V
		$I_F = 3\text{A}$			0.875	
Reverse Voltage Leakage Current	$I_R$	$V_R = 30\text{V}$			1	mA
Diode Capacitance	$C_D$	$V_R = 4\text{V}, f = 1.0\text{MHz}$			120	pF

## ■ Marking

Marking	SK
---------	----